



**WELCOME**

**PRESENTATION**

**ON**

**CONTROL OF REMOTE  
DEVICES USING TCP/IP**

**THE TERM “NETWORK-ENABLED”**  
**IS VERY BROAD, BUT GENERALLY**  
**MEANS ONE OR MORE OF THE**  
**FOLLOWING.**

- ALLOWING DATA DYNAMIC/STATIC IN THE EMBEDDED PRODUCT/DEVICE TO BE MONITORED, SOMETIMES IN A WEB PAGE, SOMETIMES THROUGH AN APPLICATION WITH NO DIRECT HUMAN INTERACTION.

- **SENDING SUPERVISORY DATA TO THE EMBEDDED PRODUCT/DEVICE VIA N/W OR MODEM.**
- **ALLOWING THE EMBEDDED DEVICE TO INITIATE AN EVENT DRIVEN E-MAIL MESSAGE, OR PROVIDING OTHER TRIGGERS FOR THE EMBEDDED DEVICE TO SEND AN E-MAIL MESSAGE.**
- **PROVIDING TRANSPARENT TCP CONNECTIONS BETWEEN THE EMBEDDED DEVICE AND A LEGACY DEVICE/EXTERNAL HARDWARE /CONTROL SYSTEM.**

# ETHERNET-ENABLED HARDWARE

- THESE HARDWARE PLATFORMS ARE ALL ESSENTIALLY LOW-COST SINGLE-BOARD COMPUTER (SBC) PLATFORMS THAT INCLUDE A 10BASE-T ETHERNET PORT, VARIOUS I/O POINTS, AND AT LEAST ONE SERIAL PORT.

# HARDWARE DESIGN

- MICRO CONTROLLER MODULES ARE COMPACT PCBS WITH BUILT IN CORE CPUs, WHICH PLUG INTO A MOTHER BOARD OF THE CUSTOMER'S DESIGN.
- INTEGRATED COMPUTER MODULES ARE IDEAL AS EMBEDDED HARDWARE PLATFORMS AS THEY INCLUDE A 10BASE-T ETHERNET PORT, THE CORE CPU, FLASH MEMORY, SRAM, LOGIC LEVEL I/O, AND LOGIC LEVEL SERIAL PORTS.



**AVAILABLE**  
**TECHNOLOGIES**

# TECHNOLOGIES

- THE AXIS NETEYE 200

- CONNECTS TO AN ETHERNET BASED NETWORK, OR A MODEM
- SUPPORT FOR HTTP AND FTP PROTOCOLS
- BASED ON A 32-BIT RISC PROCESSOR
- CAN BE USED TO CONTROL OTHER DEVICES

- DYNALOG SYSTEMS  
MOXA N-POWER  
COMMANDER

- REMOTE ON/OFF ANY UNATTENDED DEVICES
- TCP/IP ETHERNET CONTROL THROUGH PPP CONNECTION
- CONTROL VIA REGULAR TELE LINE.
- REMOTE FIRMWARE UPGRADE VIA FTP SERVER



- **EMBEDDED SYSTEMS USING SERVERS AND JAVA APPLETS DEVELOPED BY SUN MICRO SYS**

- REMOTE MACHINE CONTAINS A MINIATURE HYPERTEXT TRANSFER PROTOCOL (HTTP) SERVER
- JAVA APPLETS USED TO CONTROL THE REMOTE MACHINE
- ADVANTAGE OF USING CURRENTLY AVAILABLE TECHNOLOGY

- **PHAR LAP WEATHER STATION**

- BASED ON MICRO WEB SERVER, A WEB PAGE SERVER THAT SUPPORTS JAVA APPLETS AND THAT CAN CREATE DYNAMIC WEB PAGES THAT CHANGE DEPENDING ON REAL-TIME DATA
- WEATHER STATION IS BASED ON A 486 SINGLE BOARD COMPUTER AND PROVIDES WEATHER DATA
- CAN BE USED TO CONTROL EMBEDDED SYSTEMS, SUCH AS ORDINARY HOUSEHOLD APPLIANCES.

- **NET SILICON'S STRONG ARM BASED SOLUTION**

- 32-BIT ARM7TDMI-BASED “SYSTEM-ON-SILICON” DEVICES WITH ALL OF THE KEY FUNCTIONAL BLOCKS
- NET+ARM HAS BEEN OPTIMIZED TO WORK EFFICIENTLY ON A 10/100 BASE T LAN CONNECTION AND TO MOVE LARGE AMOUNTS OF DATA AT HIGH SPEED
- NET+15, A LOW-COST PROCESSOR SUITABLE FOR NETWORK APPLIANCE APPLICATIONS.
- NET + 50 HIGH END.

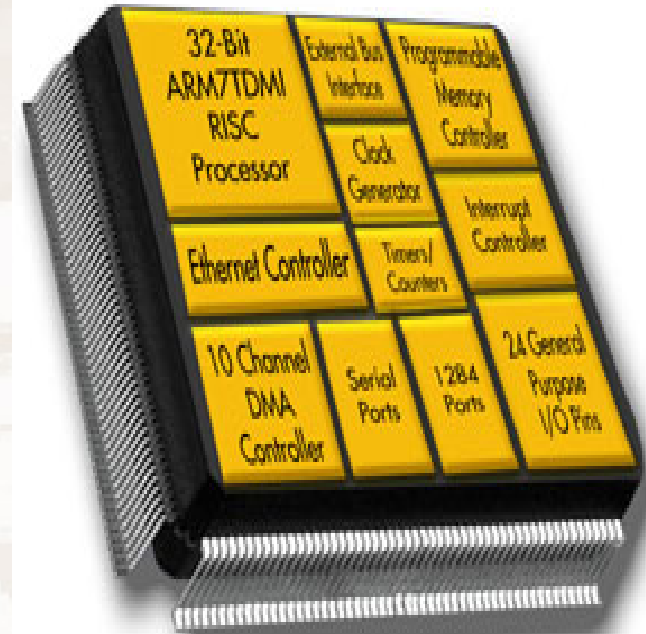

# • ETHERNET FOR FLASHLITE 386 DX

- ETHERNET
  - 10BASE-T ETHERNET
  - RJ-45 CONNECTOR
  - 16 BIT INTERFACE
  - FULL DUPLEX OPERATION
  - AUTOMATIC POLARITY  
DETECTION/CORRECTION
  - PACKET DRIVER
  - INCLUDED NE-2000  
COMPATIBLE
- COM3 } **16550 USART**
- COM4 }
- BI-DIRECTIONAL PARALLEL  
PORT

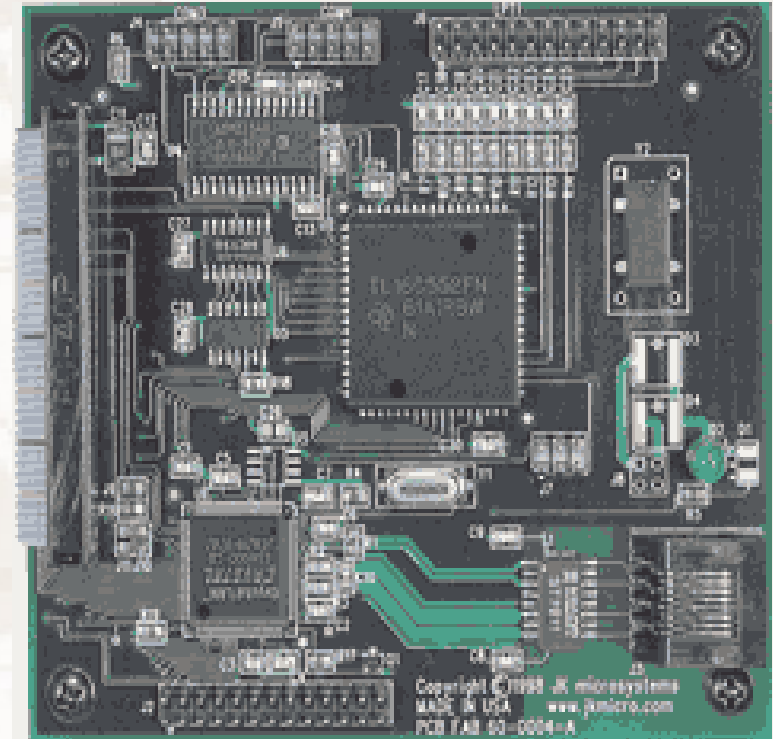

# **NOVELL'S EMBEDDED SYSTEMS TECHNOLOGY**

- (NEST) IS A SYSTEM THAT CAN BE USED TO CREATE NETWORKED EMBEDDED SYSTEMS BASED ON ANY PROCESSOR.
- PROTOCOL USED (KNOWN AS THE NEST PROTOCOL) THAT PROVIDES FOR A SECURE AND RELIABLE CONNECTION WITH AN EMBEDDED PROCESSOR OVER A NETWORK.
- A DEVICE USING THE NEST PROTOCOL CAN BE CONNECTED USING A 286-BASED BOARD WITH A 256 KILOBYTE EPROM ALONG WITH A PROGRAMMABLE INPUT/OUTPUT CHIP AND SOME LOGIC TO CONTROL THE DEVICE.

# NEST DISADVANTAGE

- SPECIALISED PROTOCOL TO COMMUNICATE WITH THE EMBEDDED SYSTEM, IT IS NECESSARY TO DEVELOP A SPECIALISED PROGRAM TO CONTROL THE APPLIANCE.
- WILL NOT RUN OFF EXISTING PLATFORMS, SUCH AS FTP AND HTTP SERVERS.

## • INTELONET

- TECHNOLOGY THAT WAS DEVELOPED BY NOVELL HAS NOW BEEN ACQUIRED BY INTELOGIS INCORPORATED
- HARDWARE TO ALLOW A NETWORK TO BE CREATED BY USING THE EXISTING POWER LINES INSIDE A HOME OR OFFICE
- HARDWARE IS KNOWN AS THE *INTELONET POWER LINE* AND IT MAKES IT POSSIBLE TO CREATE A NETWORK BY PLUGGING A DEVICE INTO A WALL OUTLET
- COMN SPEEDS OF UP TO 1 MBPS
- SOFTWARE CAN AUTOMATICALLY LOCATE AND CONFIGURE ALL SUCH DEVICES ON THE NETWORK

## • KATIX MINI-IP

- HARDWARE CONSISTS OF A MICROPROCESSOR AND AN ETHERNET CONTROLLER ALONG WITH SOME ADDITIONAL MEMORY
- SOFTWARE CONSISTS OF A BASIC OPERATING SYSTEM AND A BASIC IMPLEMENTATION OF SOME OF THE COMMUNICATION PROTOCOLS USED OVER THE INTERNET/INTRANET
- SYSTEM MASTER SLAVE CONFIG

# • VADEM VG330

- 16-BIT, 32-MHZ, X86-BASED, INFORMATION APPLIANCE REFERENCE DESIGN
- I POINT FIRMWARE HANDLES PROTOCOLS SUCH AS TCP/IP, PPP, PLUS TASKS LIKE MODEM OR ISP SETUP, AND FTP/SMTP TRANSACTIONS
- SPECIALIZED CONTROLLERS ARE BUNDLED WITH READY-MADE PROTOCOL STACKS THAT SPEED PRODUCT DEVELOPMENT AND REDUCE INTEROPERABILITY PROBLEMS
- ROM-BASED NETWORK APPLICATIONS LIKE FTP, HTTP, TELNET, POP3, AND MAIL SERVICE, AS WELL AS THE SNMP MANAGEMENT FUNCTIONS, PROVIDED.

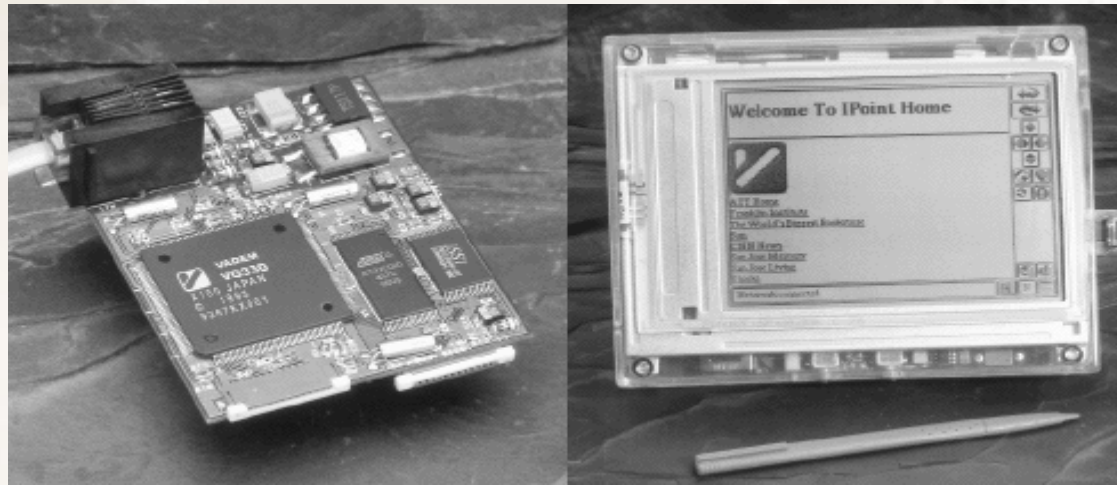

# EARLY SOLUTION

## • NETWORK REFRIGERATOR

- ONE OF THE EARLIER NETWORK REFRIGERATORS CONSISTED OF A COMPUTER WITH A MODEM, A MICROPROCESSOR AND A NUMBER OF SENSORS. THE SENSORS RECORD THE TEMPERATURE INSIDE THE FRIDGE, WHETHER THE DOOR IS OPEN OR NOT .
- THE MICRO-PROCESSOR RECEIVES THE DATA FROM THE SENSORS, PROCESSES THE DATA SO THAT THE COMPUTER CAN UNDERSTAND IT AND SENDS THE DATA TO THE COMPUTER.
- THE COMPUTER THEN INSERTS THE DATA INTO A WEB PAGE THAT CAN BE OBTAINED FROM ITS WEBSITE.

# DISADVANTAGE

- MAIN DISADVANTAGE IS THAT THE MICRO-PROCESSOR MUST COMMUNICATE THROUGH A COMPUTER AND IS NOT DIRECTLY CONNECTED TO THE INTERNET. A DIRECT CONNECTION TO THE INTERNET WOULD REQUIRE FEWER COMPONENTS, TAKE UP LESS SPACE AND BE A LOT CHEAPER.

# PRESENT APPROACH

- USE OF NET ENABLED EMBEDDED COMPUTER
- MORE NO OF SENSORS
- ARTIFICIAL INTELLIGENCE
- E-COMMERCE CAPABLE
- NET SECURITY
- USER IDENTIFICATION / PASSWORD AUTHENTICATION
- VOICE ACTIVATED
- PROGRAMMABLE VIA FTP

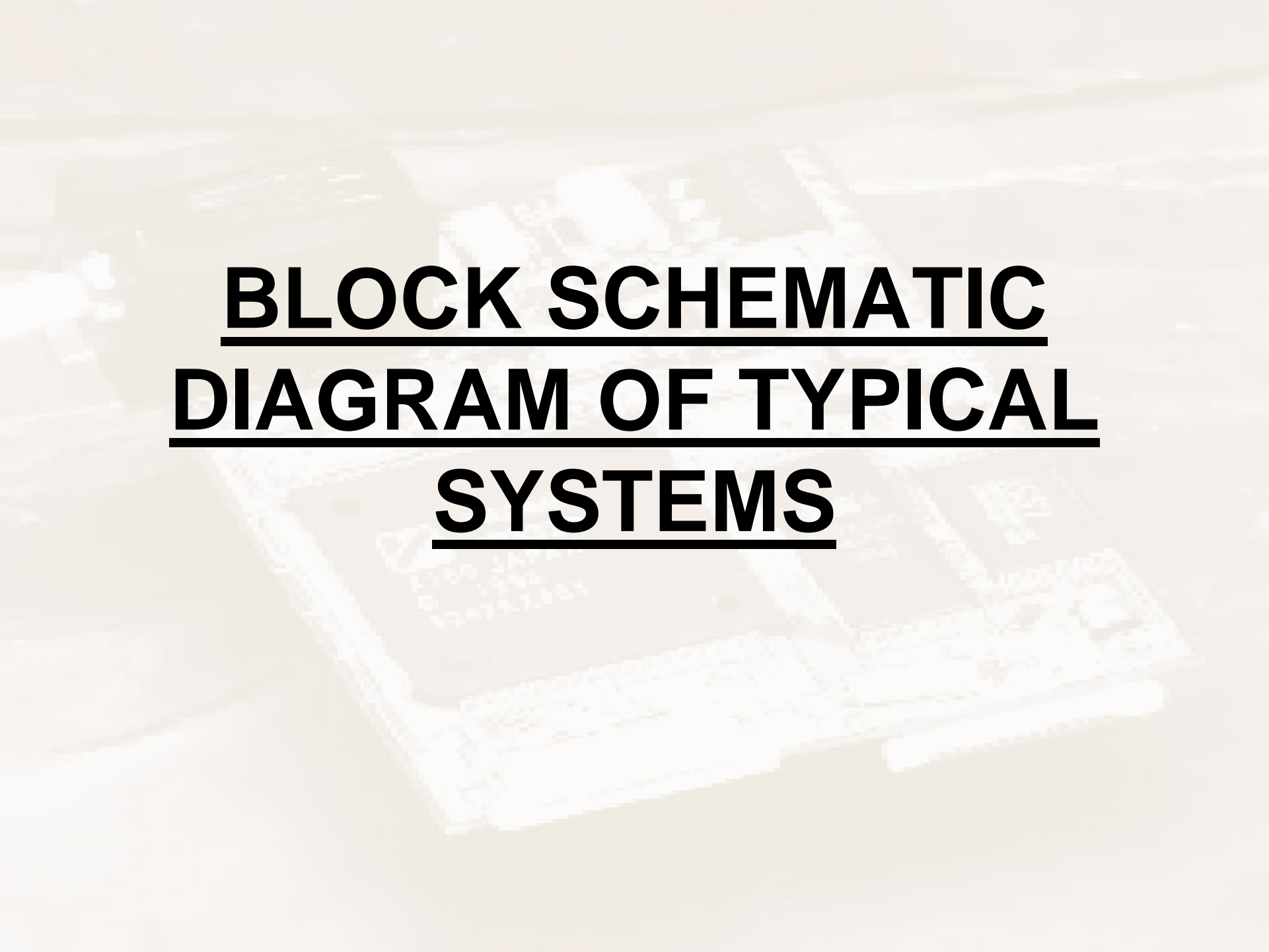

**BLOCK SCHEMATIC**  
**DIAGRAM OF TYPICAL**  
**SYSTEMS**

# BLOCK SCHEMATIC

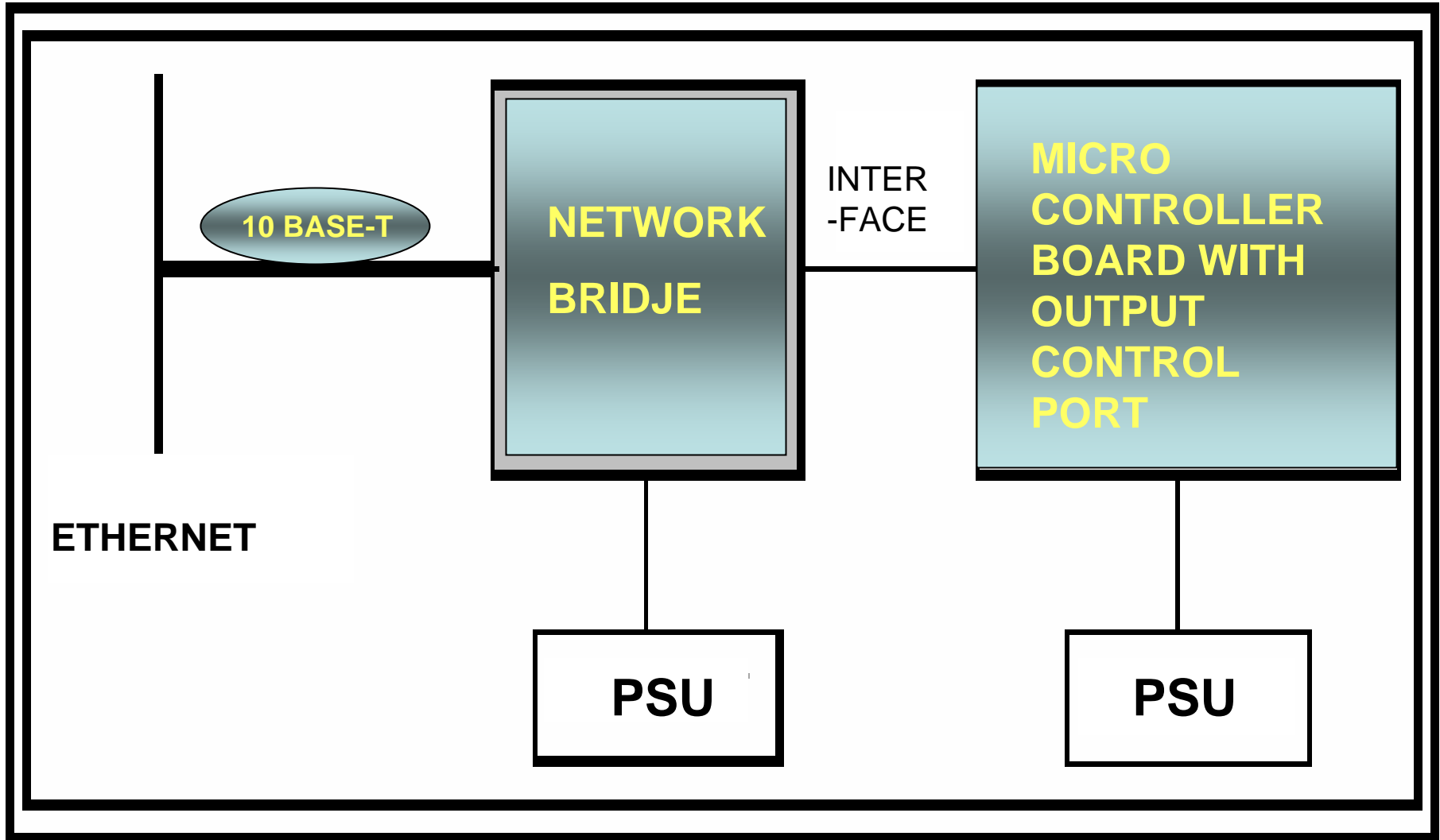

# BLOCK SCHEMATIC

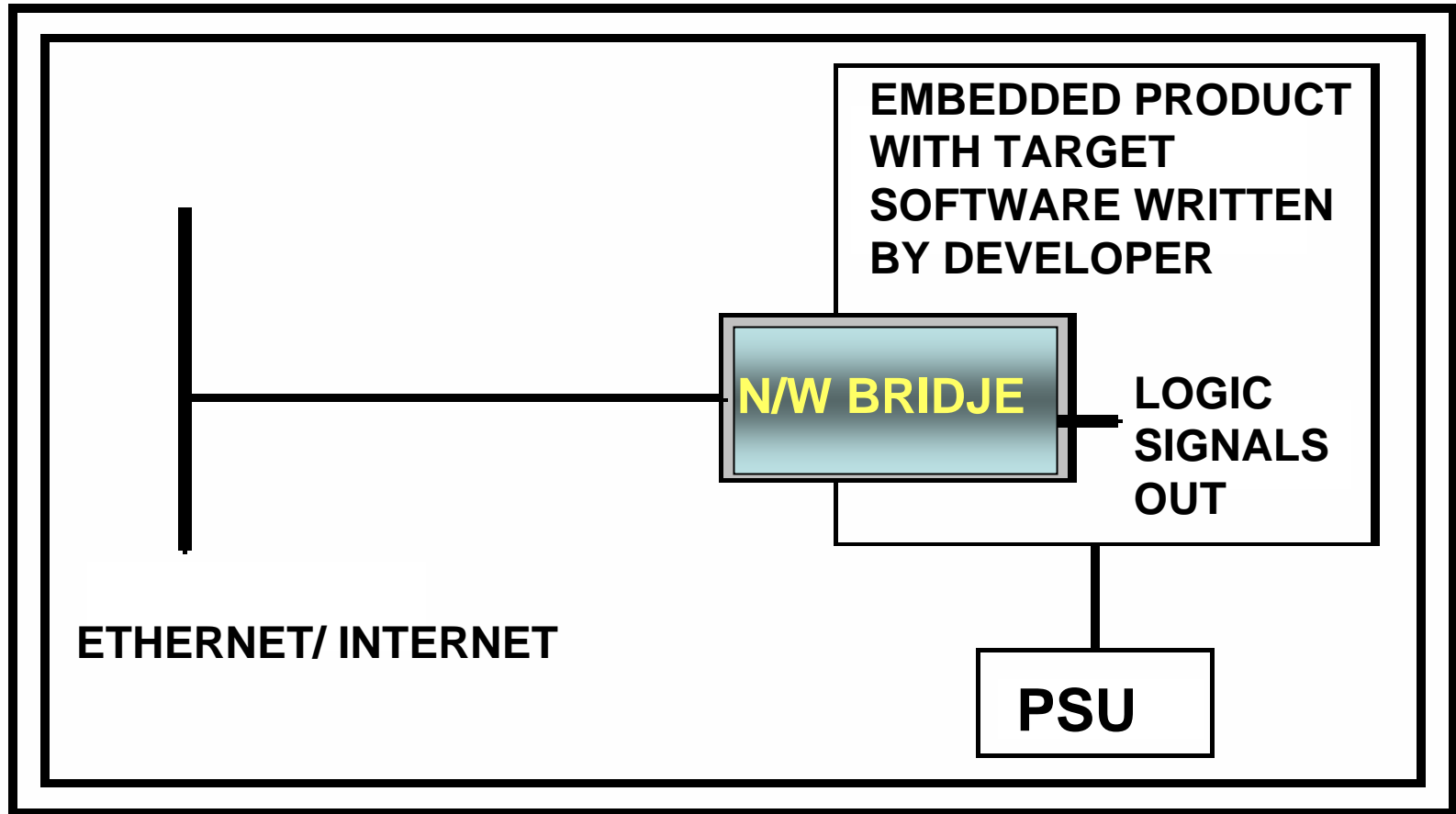



**A TYPICAL MODERN**  
**MICROCONTROLLER**

# MICROCONTROLLER

16/32/64 BIT RISC CORE PROCESSOR	BUS INTERFACE		PROGRAMMABLE MEMORY CONTROLLER	F L S H R A M 2 5 6 K
	CLOCK GENR			
ETHERNET CONTROLLER	TIMER AND COUNTERS		INTERRUPT CONTROLLER	
	DMA CONTROLLER	SERIAL AND PARALLEL PORTS	SPECIAL PORTS	

An aerial photograph of a city, likely Tokyo, showing a dense grid of buildings and streets. The image is overlaid with a large, bold, black text 'PROTOCOLS' that is underlined. The text is centered horizontally and vertically on the image. The background is a light, desaturated color, possibly due to a filter or the way the image was processed.

# PROTOCOLS

# PROTOCOLS

HyperText Transfer Protocol	File Transfer Protocol
Transmission Control Protocol	
Internet Protocol	
Address Resolution Protocol	

# LAYERS OF TCP/IP PROTOCOL SUITE

Application	FTP, HTTP
Transport	TCP, UDP
Network	IP, ICMP
Link	ARP, PPP

- THE LINK LAYER IS RESPONSIBLE FOR THE TRANSMISSION AND RECEPTION OF THE ACTUAL DATA FROM AND TO THE COMPUTER . ADDRESS RESOLUTION PROTOCOL (ARP) ( ETHERNET NETWORKS) AND THE POINT TO POINT PROTOCOL (PPP) (SERIAL TRANSMISSIONS SUCH AS THROUGH A MODEM)
- NETWORK LAYER USES THE INTERNET PROTOCOL (IP). THE MAIN PURPOSE OF IP IS TO FORWARD DATA TO IT'S CORRECT DESTINATION. IP ALSO PROVIDES A MECHANISM FOR FRAGMENTING LARGE PACKETS. INTERNET CONTROL MESSAGE PROTOCOL (ICMP) IS USED TO SEND ERROR AND CONTROL MESSAGES THAT ARE USEFUL IN DEBUGGING PROBLEMS WITH A NETWORK

- TWO COMMON TRANSPORT PROTOCOLS USER DATAGRAM PROTOCOL (UDP) AND THE TRANSMISSION CONTROL PROTOCOL (TCP). UDP IS SIMPLE, NOT VERY COMPLICATED, BUT NOT VERY RELIABLE. TCP PROVIDES FOR A RELIABLE FLOW OF DATA BETWEEN COMPUTERS MORE POPULAR
- SOME APPLICATION LAYER PROTOCOLS ARE THE SIMPLE NETWORK MANAGEMENT PROTOCOL (SNMP) IS USED TO ACCESS NETWORK STATISTICS ABOUT A COMPUTER AND TO NOTIFY A NETWORK MANAGER WHEN A PROBLEM OCCURS IN A COMPUTER IT IS USUALLY BASED ON (UDP).

- THE HYPERTEXT TRANSFER PROTOCOL (HTTP) IS USED TO OBTAIN WEB PAGES AND GRAPHICS FROM A REMOTE SITE. IN GENERAL, A REQUESTS FOR A WEB PAGE IS RECEIVED AND THAT PAGE IS TRANSMITTED BACK TO THE REQUESTING MACHINE THROUGH THE USE OF TCP WHERE THE WEB BROWSER DISPLAYS THE PAGE ON THE SCREEN.
- THE FILE TRANSFER PROTOCOL (FTP) IS SIMILAR TO HTTP EXCEPT THAT THE REQUESTED FILE IS STORED ON THE HARD DRIVE OF THE RECEIVING MACHINE AND THE TRANSFER OF FILES CAN HAPPEN IN EITHER DIRECTION. A FILE CAN BE TRANSFERRED TO OR FROM A REMOTE COMPUTER



# **SOFTWARE DESIGN**

# TARGET SOFTWARE

- REGARDLESS OF HARDWARE PLATFORM SOME SOFTWARE IS REQUIRED TO BE WRITTEN OR MODIFIED FOR USE ON THE TARGET DEVICE BASED ON SOME PROCESSOR.
- IF THE TARGET DEVICE IS KIT BASED THEN PRE-WRITTEN ROUTINES ARE AVAILABLE TO MINIMIZE THE SOFTWARE DEVELOPMENT TASK AT THE TARGET. IF THE MICROPROCESSOR ON THE TARGET DEVICE IS NOT KIT BASED THEN, ANSI C ROUTINES ARE AVAILABLE, BUT THE HARDWARE LEVEL DRIVERS MUST BE PORTED FOR THAT PROCESSOR.
- IF THE TARGET CPU IS NOT SUPPORTED OUT OF THE BOX, THEN EXPERIENCED PROGRAMMERS CAN EXAMINE THE SAMPLE TARGET CODE AND PORT IT TO THEIR OWN CPUS.

# PROTECTION PROBLEM

Protection Rings

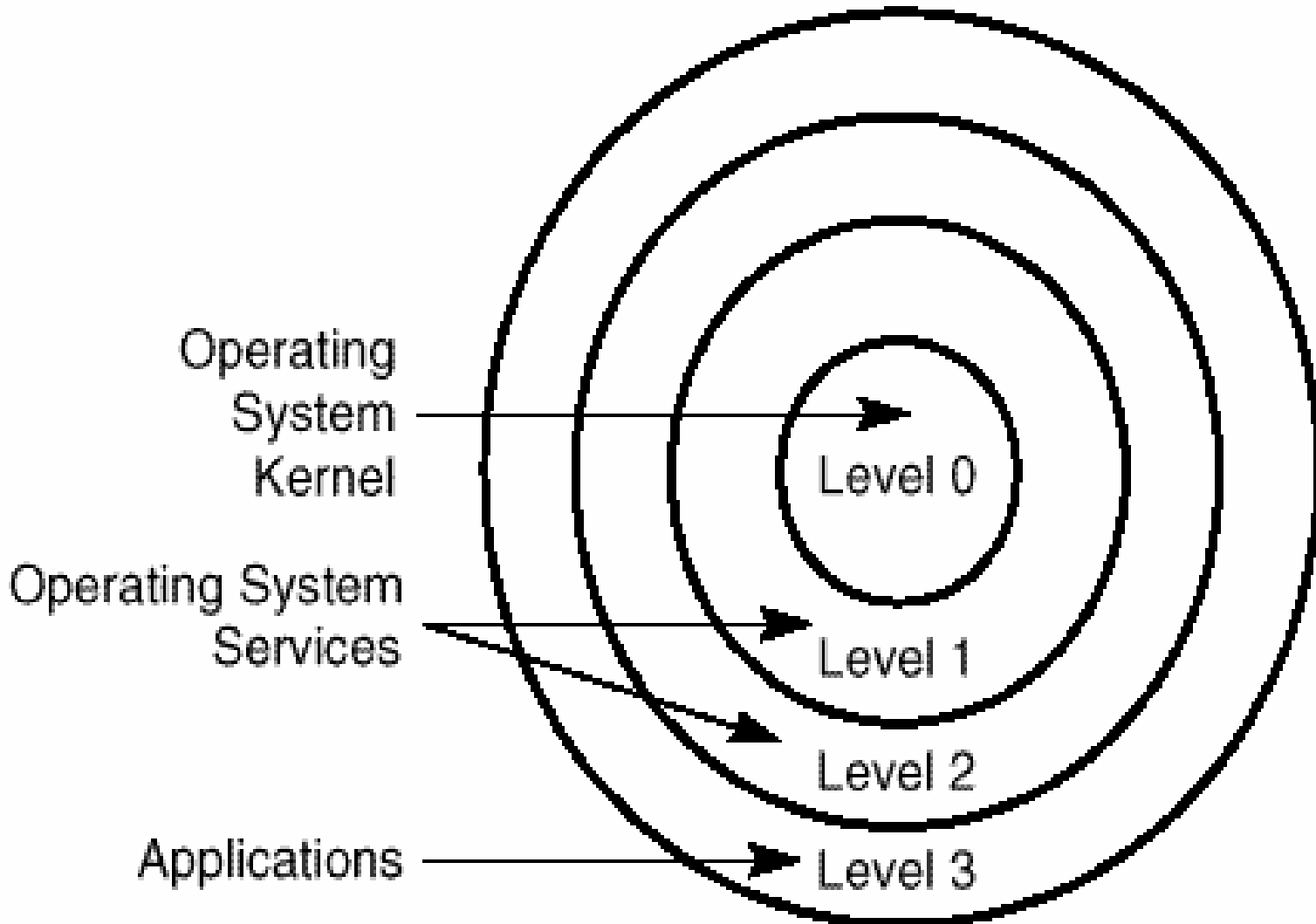

# APPLICATIONLESS APPROACH

- USE TCP/IP PROTOCOL SUITE.
- THESE ARE THE FILE TRANSFER PROTOCOL (FTP), TO ALLOW THE SOFTWARE ON THE PROCESSOR TO BE UPGRADED REMOTELY OVER A NETWORK.
- AND THE HYPERTEXT TRANSFER PROTOCOL (HTTP) TO ALLOW STATUS INFORMATION ABOUT THE REMOTE MACHINE TO BE OBTAINED AND THE REMOTE MACHINE TO BE CONTROLLED VIA A WEB PAGE.

# ADVANTAGES

- EASE OF USE AND NO APPLICATION MUST BE DEVELOPED IN ORDER TO CONTROL THE REMOTE MACHINE.
- ANY ERROR INFORMATION CAN BE PROVIDED ON THE WEB PAGE THAT CONTAINS THE STATUS OF THE REMOTE MACHINE.
- IT IS ALSO NECESSARY TO PREVENT TWO REMOTE USERS FROM ATTEMPTING TO CONTROL THE REMOTE MACHINE SIMULTANEOUSLY, ACCOMPLISHED BY ALLOWING ONLY ONE REQUEST TO THE HTTP SERVER AT A TIME AND IGNORING ALL OTHERS. IN OTHER WORDS, THE PROCESSOR WILL FINISH SERVICING ONE REQUEST BEFORE SERVICING A SECOND

# DIFFERENCE IN EMBEDDED SERVER

- THIS IS QUITE DIFFERENT FROM MOST WEB SERVERS WHICH ARE CAPABLE OF SERVICING MANY REQUESTS AT THE SAME
- SOFTWARE SHOULD ALSO BE ABLE TO ACCEPT INPUTS FROM THE LOCAL CONTROLS AND DETERMINE WHETHER THE REMOTE MACHINE IS CONFIGURED FOR LOCAL OR REMOTE USE.

An aerial photograph of a city grid, likely New York City, showing a dense pattern of streets and buildings. The image is semi-transparent, allowing the text to be clearly visible. The text is centered and reads "AVAILABLE PRODUCTS" in a large, bold, black font.

# AVAILABLE PRODUCTS

# ETHERNET TO SERIAL CONVERTER USING MOTOROLA MC68HC11K MICROCONTROLLER

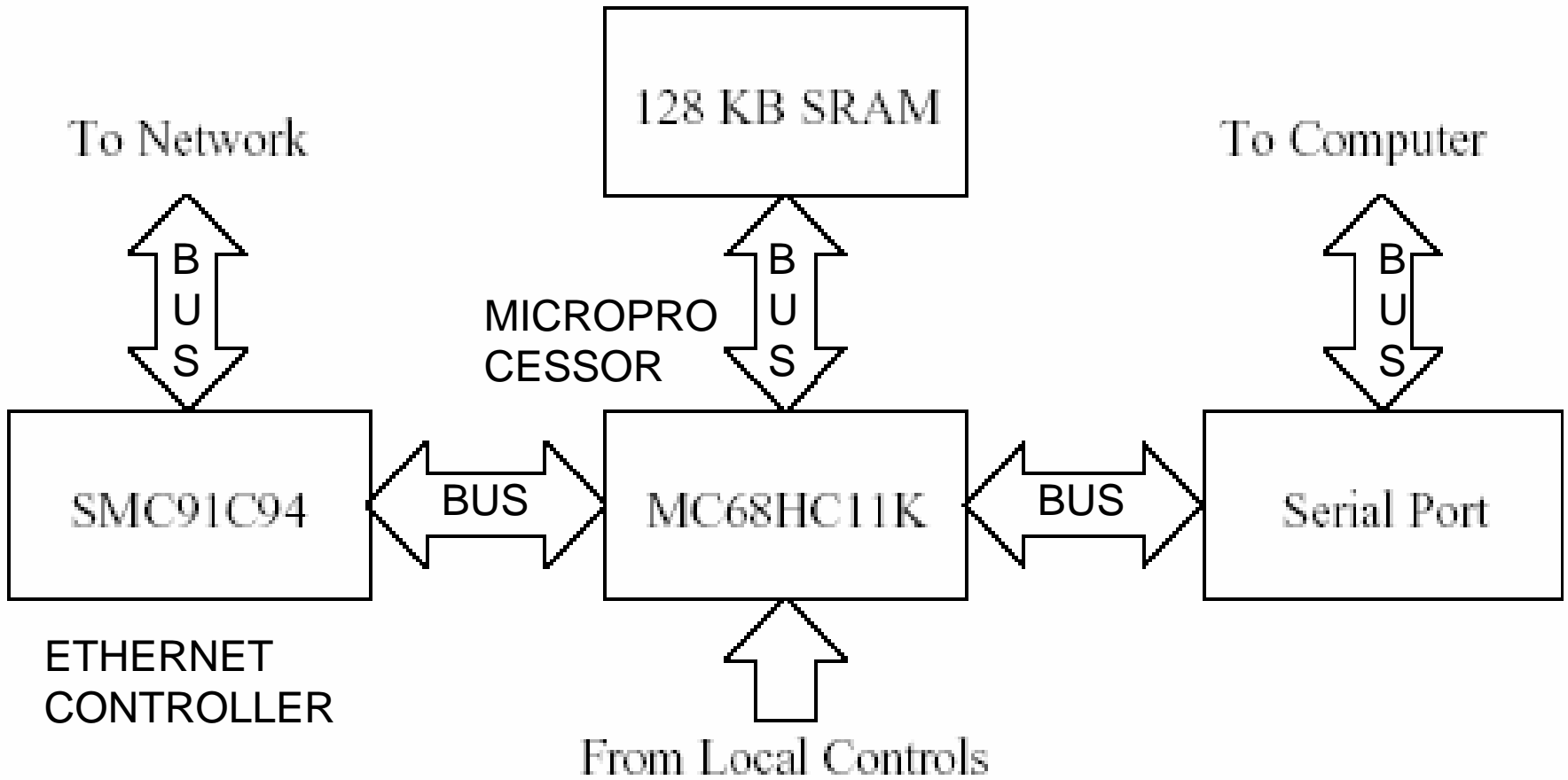

# ETHERPATH® SS-1 SS-2 SINGLE PORT SERIAL SERVER



BACK VIEW



FRONT VIEW

# MULTI PORT CONVERTERS



# LANTRONIX MSS100 FAST ETHERNET MICRO SERIAL SERVICES

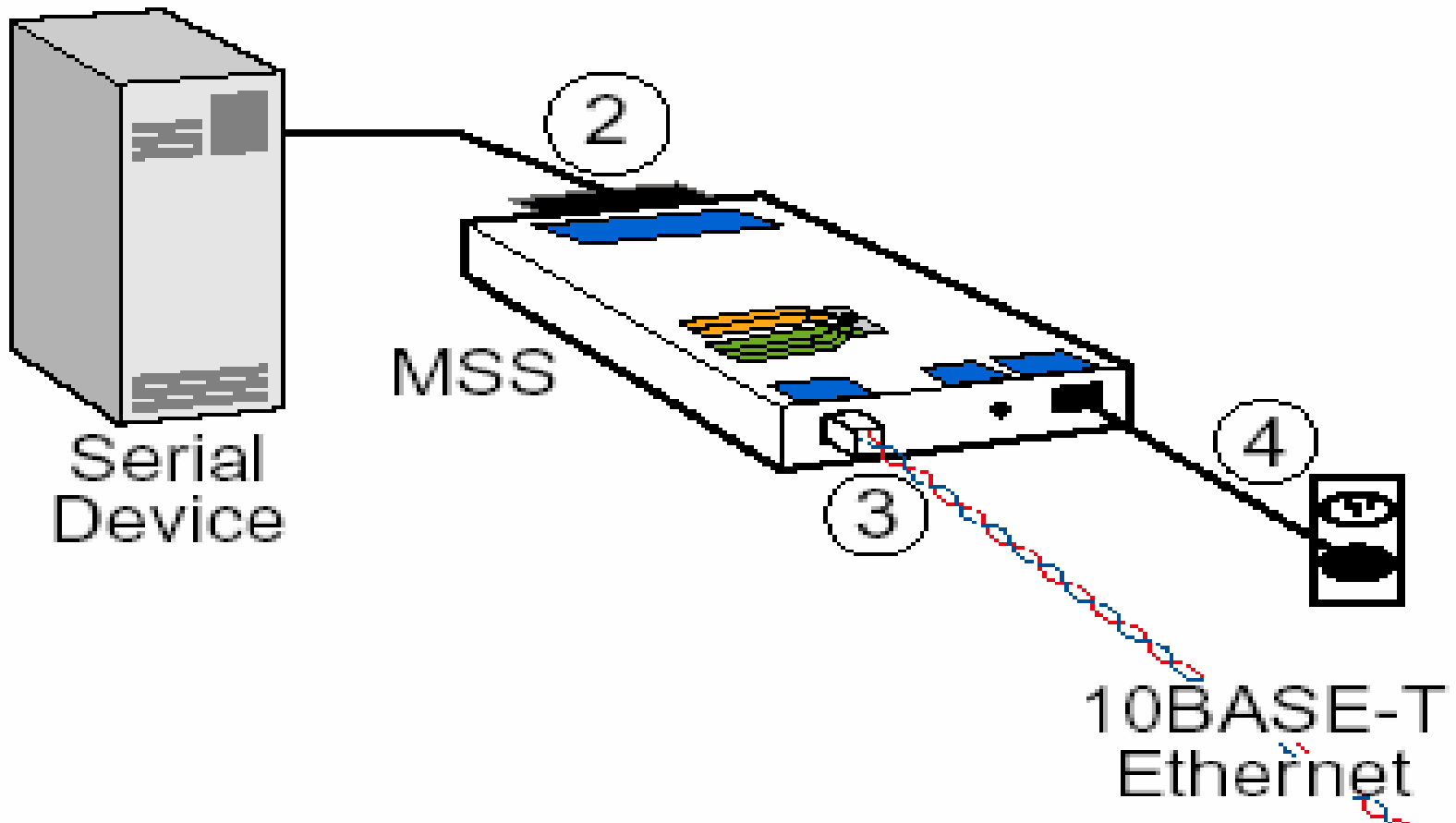

# ETHERNET TO PARALLEL ADAPTER FROM SBIG



# WIRELESS ETHERNET SERVER AND USB 2.0 TO ETHERNET CONVERTER AND SERVER

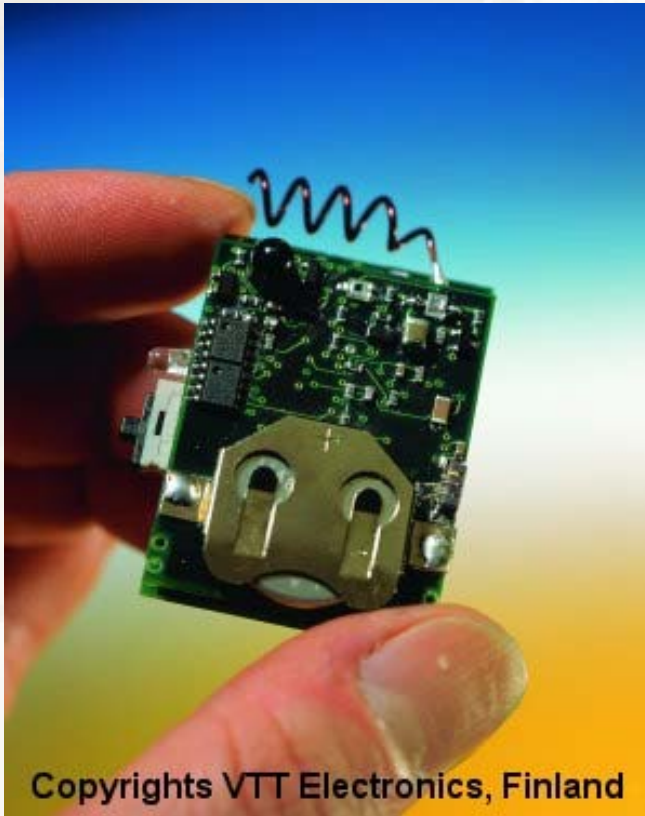

Copyrights VTT Electronics, Finland



# TROY XCD RANGE OF 10BASE-T ETHERNET SERIAL SERVER



# The Digital Home

Any Content, Any Place, Any Device, Any Time



# INTEL'S RESIDENTIAL GATEWAYS

- **Intel® IXP425-Based Residential Gateway**

- Flexible Design Supports Multiple Platforms
- Support for Advanced Feature Sets
  - 802.11 AP

- **CableHome\* Residential Gateway**

- Standards Driven design
- Growing Network Processing Workload
- Linux

## Intel® IXP425 RG

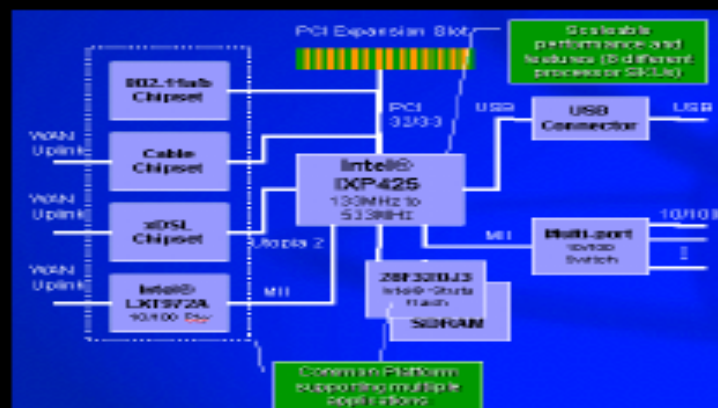

## Reference Design Kit

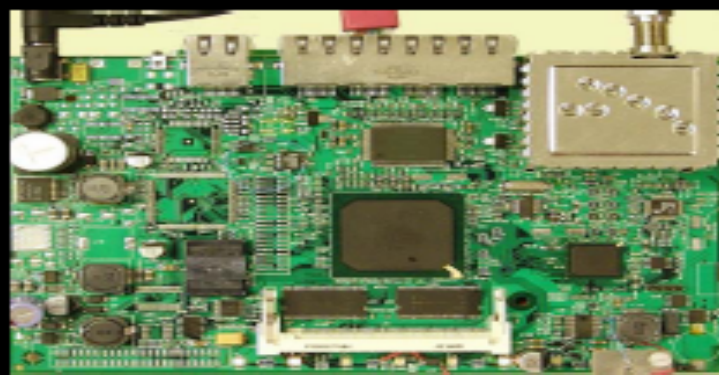

# Intel® IXA Network Processor Solutions

- Intel® IXA Solutions
  - Intel® XScale™ Micro-architecture
  - Micro-engine Technology
  - Intel® IXA Portability Framework
- Family of Network Processors
  - Intel® IXP425
  - Intel® IXP2400
  - Intel® IXP2800
- Comprehensive Development Environment
- Advanced Tools and Techniques to Simplify Intel's Network Processor Software

## Intel® IXA Model

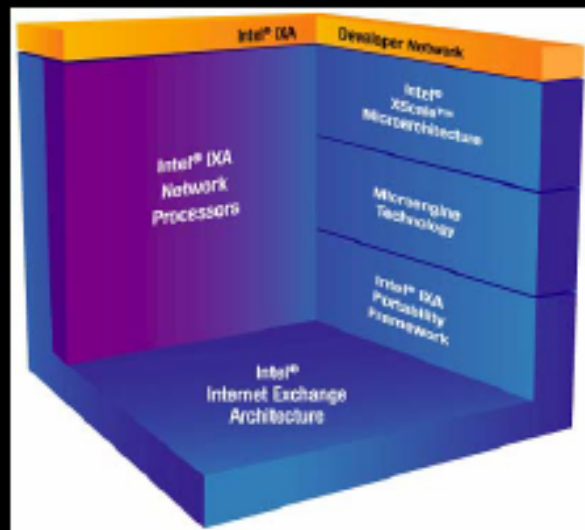

## Tools Speed Development



Hardware  
Development  
Platform



Software  
Tools



# CONTROL CIRCUITS



# CONTROL CIRCUITS

*Circuit for connecting  
one device*

PARALLEL  
PORT

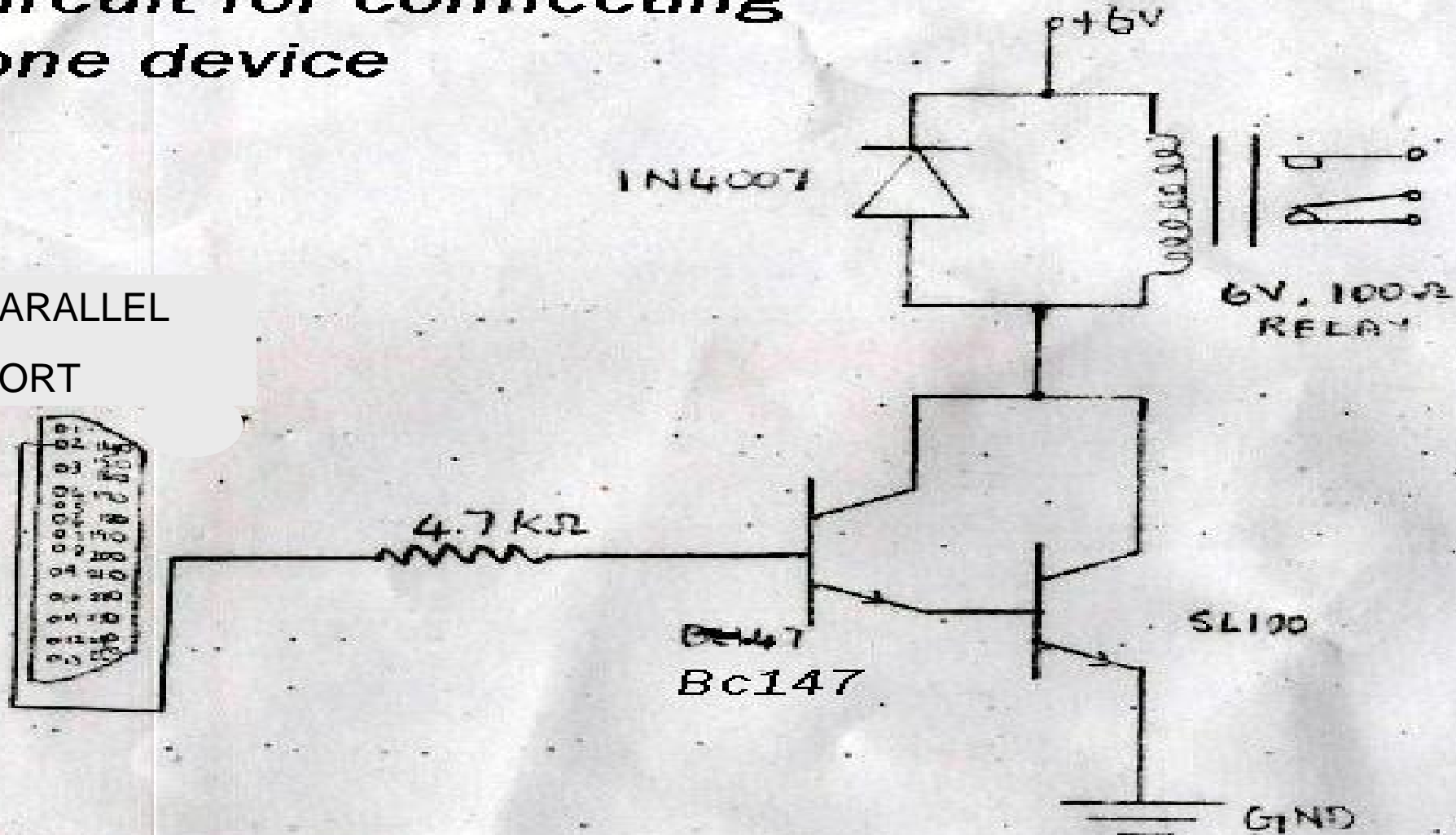

An aerial photograph of a city, likely Tokyo, showing a dense urban layout with a prominent grid pattern. The word "SECURITY" is overlaid in the center in a large, bold, black, sans-serif font, underlined. The background is a light, desaturated color, possibly a faded or high-key version of the original image.

# SECURITY

# **SECURITY FEATURES**

- THE MOST IMPORTANT AREA OF SECURITY IS WITH FTP WHEN UPGRADING SOFTWARE.
- USE OF A SECURE LOGIN NAME AND PASSWORD FOR REMOTE USER.
- PERMIT COMPUTERS WITH AN INTERNET ADDRESS WITHIN A CERTAIN RANGE TO CONTROL THE REMOTE MACHINE.
- STATUS INFORMATION -EVERYONE.

# INTRUDER DETECTION AND ALARM

**SYSTEMS CAN  
RAISE ALARM AND  
AUTOMATICALLY  
INFO SYSTEM  
ADMINISTRATORS**

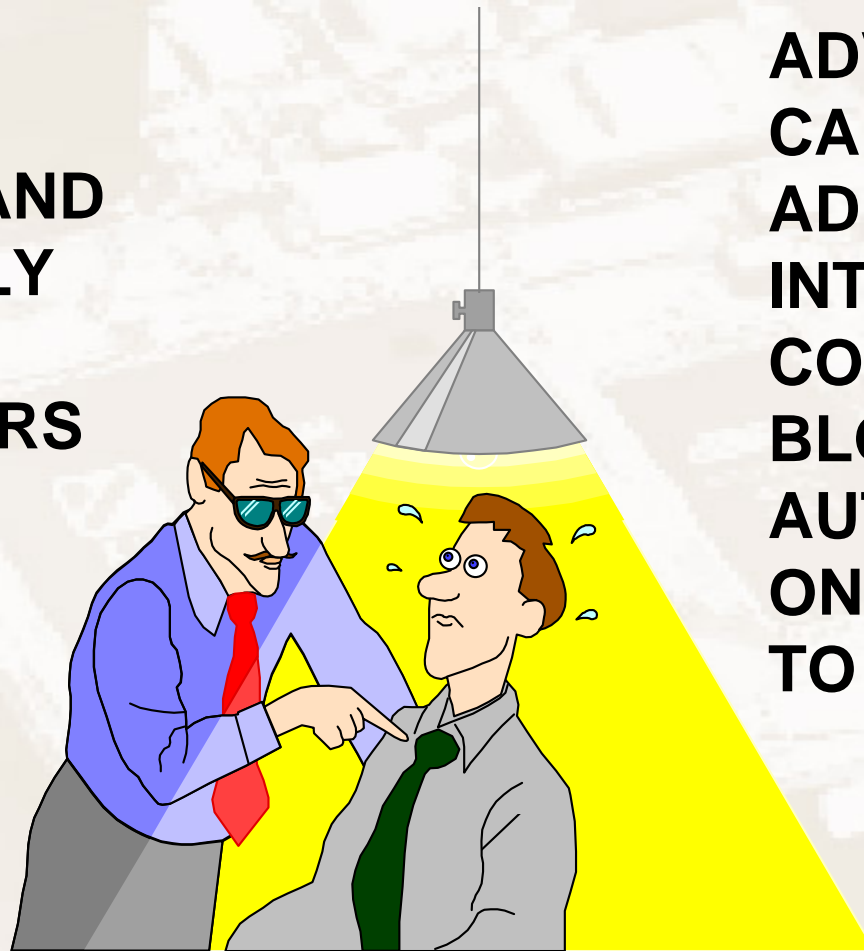

**ADVANCED SYS  
CAN FIND OUT IP  
ADDRESS OF  
INTRUDERS  
COMPUTER AND  
BLOCK IT  
AUTOMATICALLY  
ON NEXT ATTEMPT  
TO LOGIN**

# YOUR QUERIES

